



FLUID MANAGEMENT CURRENT & IN DEVELOPMENT



PT[®]
Performance Tool

MECHANICS
Products

PROJECT
PRO[™]



POWER **airTIGHT**

Northwest
Trail

ATAK[™]



DRAIN CONTAINERS

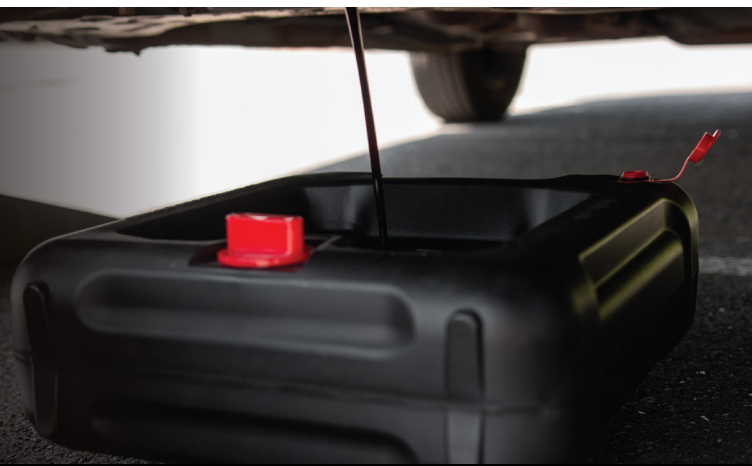

Wilmar, LLC • Performance Tool • Mechanics Products • Project Pro • PT Power • Firepoint X • Northwest Trail • airTIGHT • ATAK



10 QUART OIL DRAIN CONTAINER

Item	Cross Part Number	Inner	Master	UPC
W4076	42001MI	1	6	039564153181

- Heavy wall construction keeps container rigid, even when draining hot engine oil
- Integrated handles for convenient carrying, pouring, and transport to recycling center
- Deep drain well with angled sides minimize splashing and spilling during oil draining
- High quality tethered plastic caps with rubber gaskets for a leak free seal
- Made from durable polypropylene material
- 10 Quart (9.46 L) capacity



16 QUART OIL DRAIN CONTAINER

Item	Cross Part Number	Inner	Master	UPC
W4077	42003MI	1	4	039564015311

- Heavy wall construction keeps container rigid, even when draining hot engine oil
- Integrated handles for convenient carrying, pouring, and transport to recycling center
- Deep drain well with angled sides minimize splashing and spilling during oil draining
- High quality tethered plastic caps with rubber gaskets for a leak free seal
- Made from durable polypropylene material
- 16 Quart (15.14 L) capacity



Wilmar, LLC • Performance Tool • Mechanics Products • Project Pro • PT Power • Firepoint X • Northwest Trail • airTIGHT • ATAK



24 QUART OIL DRAIN CONTAINER

Item	Cross Part Number	Inner	Master	UPC
W4078	42004MI	1	2	039564153198

- Heavy wall construction keeps container rigid, even when draining hot engine oil
- Integrated handles for convenient carrying, pouring, and transport to recycling center
- Deep drain well with angled sides to minimize splashing and spilling during oil draining
- High quality tethered plastic caps with rubber gaskets for a leak free seal
- Made from durable PP material
- 24QT (22.71L) Capacity



ZERO SPLASH 16 QT. DRAIN CONTAINER & FUNNEL

Item	Cross Part Number	Inner	Master	UPC
W4082	421132MI	1	4	039564157707

- Innovative design features a collapsing receiver funnel that can be adjusted up to 10 in. (25 cm) off the surface of the drain pan
- Funnel surfaces engineered with splash reducing surface to reduce spillage typical with hot engine oil
- Adjustable height brings the opening closer to the drain plug to help eliminate messes
- High quality tethered plastic caps with rubber gaskets for a leak free seal
- Made from durable polypropylene and silicone material
- 16 Quart (15.14 L) capacity



UNDER DEVELOPMENT:
IN STOCK Q2 2026

Wilmar, LLC • Performance Tool • Mechanics Products • Project Pro • PT Power • Firepoint X • Northwest Trail • airTIGHT • ATAK



16 QUART CLEAR VIEW OIL DRAIN CONTAINER

Item	Cross Part Number	Inner	Master	UPC
W4080		1	4	039564015830

- Heavy wall construction keeps container rigid, even when draining hot engine oil
- Integrated handles for convenient carrying, pouring, and transport to recycling center
- Deep drain well with angled sides minimize splashing and spilling during oil draining
- High quality tethered plastic caps with rubber gaskets for a leak free seal
- Made from durable polypropylene material
- 16 Quart (15.14 L) capacity



12 QT. USED/RECYCLED OIL CONTAINER

Item	Cross Part Number	Inner	Master	UPC
W4067	11849MI	1	10	039564156380

- Large capacity recycling jug makes it easy to bring your used oil or other fluids to your local recycling center
- Chemical and solvent resistant construction for durability and safe handling
- Integrated molded handle provides convenient carrying and pouring
- Wide-mouth opening ensures easy, spill-free pouring
- 12-Quart (3-Gallon, 11.4 L) capacity



Wilmar, LLC • Performance Tool • Mechanics Products • Project Pro • PT Power • Firepoint X • Northwest Trail • airTIGHT • ATAK



DRAIN PANS



Wilmar, LLC • Performance Tool • Mechanics Products • Project Pro • PT Power • Firepoint X • Northwest Trail • airTIGHT • ATAK



2-IN-1 DRAIN PAN TOOL CADDY

Item	Cross Part Number	Inner	Master	UPC
W4074		1	1	039564145889

- Oil drain pan and mobile tool caddy, two tools in one
- Use together when changing oil, or separately keeping your tools organized while under the car
- Unique splash guard and oil filter drain post on an 8 liter drain pan, perfect for any shop
- Three 2 in. locking swivel casters hold the caddy and pan in place when draining oil
- Oil drain pan is designed to cradle into the tool caddy making the pan mobile, easy to position
- 18-1/2 in. wide hexagon shape, 5-3/8 in. tall



4-1/2 GALLON OIL DRAIN PAN

Item	Cross Part Number	Inner	Master	UPC
W4071		1	5	039564128264

- Oil drain pan is ideal for collecting engine oils or coolants during servicing with its wide opening
- Molded high density polyethylene for long lasting durability. Easily wipes clean
- Internal anti-splash lip contains fluid when moving, or pouring
- Built in pour spout for quick, easier transferring of fluids
- Large molded handle helps make carrying stable to avoid spills
- Excess capacity helps prevent overflow or spillage, total capacity 4.5 gallons (16 liter)
- Heavy-wall construction stays rigid, even with hot engine oil



Wilmar, LLC • Performance Tool • Mechanics Products • Project Pro • PT Power • Firepoint X • Northwest Trail • airTIGHT • ATAK



7-1/2 GALLON DRAIN TUB

Item	Cross Part Number	Inner	Master	UPC
W4072		1	5	039564128721

- Large drain pan is ideal for collecting engine fluids during servicing with its wide opening
- Built in basin surface facilitates washing and sorting of smaller parts
- High density Polyethylene construction stays rigid, even with hot oil
- Excessive size helps prevent overflow or spillage, total capacity 7.5 gallons (28.4 liter)
- Overall tub size is 33 inch. X 22 inch. X 8 inch



11 QUART OIL DRAIN PAN

Item	Cross Part Number	Inner	Master	UPC
W4079	05080MI	1	10	039564153211

- Rectangular shape is designed to better collect oil and prevents messy spills without having to move the pan around
- High-capacity volume is large enough to hold up to two oil changes or 11 quarts of oil (10 L) or a complete radiator flush
- Made from durable, chemical-resistant plastic, this oil drain pan is built to last and perfect for your garage
- Convenient integrated oil filter stand allows you to drain the excess oil in filter without getting it messy
- All-around hand grips provide easy carrying, maneuvering, and pouring through a recessed corner spout
- Dimensions: 22.4 x 12.6 x 4.1 in. (570 x 320 x 105 mm)



Wilmar, LLC • Performance Tool • Mechanics Products • Project Pro • PT Power • Firepoint X • Northwest Trail • airTIGHT • ATAK



2.8 QT LOW PROFILE OIL DRAIN PAN

Item	Cross Part Number	Inner	Master	UPC
W4073		1	20	039564014345

- Low profile tapered end prevents spills when draining oil from lawn equipment and motorcycles
- The narrow end fits nicely against the engine just under the drain plug of most small engines
- Curved with splash guard lip to protect from splashing and spilling
- Made of heavy duty, chemical resistant plastic
- Capacity: 2.8 qts. (2.64L)
- Dimensions: 15.9 in. (40.38cm) x 8.5 in. (21.59cm) x 2.68 in. (6.81cm)
- Works well for motorcycles up to 1000cc



7 QT. PLASTIC DRAIN PAN

Item	Cross Part Number	Inner	Master	UPC
W4070	OP112	1	12	039564102950

- Molded handles and pour spout
- Easy to use
- Chemical and solvent resistant, won't rust or corrode
- Dimensions: 13 1/2" x 11" x 4"



Wilmar, LLC • Performance Tool • Mechanics Products • Project Pro • PT Power • Firepoint X • Northwest Trail • airTIGHT • ATAK



3-1/2 GAL. GALVANIZED DRAIN PAN

Item	Cross Part Number	Inner	Master	UPC
W54280	LX-1709	1	12	039564542800

- Made from galvanized steel for strength and corrosion resistance, even in the presence of hot fluids
- 3.5-gallon capacity to handle a high volume of fluids draining from the vehicle
- Measures 16 in. in diameter and approximately 4 in. deep
- Features a rolled edge for added rigidity and strength
- Slight baffles/ridges along the bottom to prevent splashing and spills



20 QT. EXTRA LARGE DRAIN PAN

Item	Cross Part Number	Inner	Master	UPC
W4081	42010MI	1	12	039564157578

- For large oil changes and radiator flushes
- Handles the messiest DIY jobs
- Built in pour spout for quick clean and easy recycling
- Textured pan floor to reduce splatter
- Integrated handle for easy carrying and handling



Wilmar, LLC • Performance Tool • Mechanics Products • Project Pro • PT Power • Firepoint X • Northwest Trail • airTIGHT • ATAK



8 QT. DRAIN PAN W/ FILTER HOLDER

Item	Cross Part Number	Inner	Master	UPC
W4083	42108MI	1	12	039564157615

- Ideal for draining oil, coolant, transmission fluid, and other automotive fluids during maintenance and repairs
- Made from high-quality, durable plastic designed to withstand heavy use and resist cracking or warping
- Features a low-profile design for stability, ensuring a secure surface to catch and contain fluids while preventing spills
- Each pan measures 16.5" L x 15" W x 4" H, providing ample capacity while being compact enough for easy storage and use



CLEAR VIEW 7 QT. PLASTIC DRAIN PAN

Item	Cross Part Number	Inner	Master	UPC
W4068	OP1	1	12	039564151170

- Transparent polypropylene construction allows quick and easy monitoring of liquid
- Molded handles and pour spout are easy to use
- Chemical and solvent resistant, won't rust or corrode
- Dimensions: 13-1/2 x 11 x 4 in. (343x 279 x 102 mm)
- Approximate capacity: 7 quarts, 1.75 gallons, 6.6 liters



Wilmar, LLC • Performance Tool • Mechanics Products • Project Pro • PT Power • Firepoint X • Northwest Trail • airTIGHT • ATAK



22" X 22" PLASTIC DRIP TRAY

Item	Cross Part Number	Inner	Master	UPC
W4062	40092	1	12	039564156366

- Great for any area where you may experience drips or leaks
- Helps protect many areas of your home and car such as garage floors, car trunks and laundry rooms
- Built-in lip and pour spout make it easy to carry and empty spilled fluids
- Constructed from chemical resistant polypropylene plastic
- 22 in. (558 mm) x 22 in. (558 mm) x 2 in. (50 mm) overall size
- 20 in. (508 mm) x 20 in. (508 mm) inside floor size



FOLDING SPLASH PAD

Item	Cross Part Number	Inner	Master	UPC
W4089		1	60	039564015755

- Protects surfaces during oil changes, tool cleaning, and part organization.
- 22" x 26", foldable and portable, perfect for automotive maintenance
- Brass buckles secure corners to prevent spills of oil, grease, or debris
- Easy to clean & foldable for convenient storage
- High-density wear resistant PE fabric and double sided waterproof layer



Wilmar, LLC • Performance Tool • Mechanics Products • Project Pro • PT Power • Firepoint X • Northwest Trail • airTIGHT • ATAK



25" X 36" GALVANIZED DRIP PAN

Item	Cross Part Number	Inner	Master	UPC
W4048	DP-10	1	8	039564154546

- Heavy gauge galvanized steel construction
- Overall size 25 in. x 36 in. x 0.75 in. (635 mm x 915 mm x 19 mm)
- Great for catching fluid leaks under vehicles
- Helps protect work surface during dirty jobs
- Easy to clean surface



Wilmar, LLC • Performance Tool • Mechanics Products • Project Pro • PT Power • Firepoint X • Northwest Trail • airTIGHT • ATAK



CLEAR VIEW™ & OTHER FUNNELS

Wilmar, LLC • Performance Tool • Mechanics Products • Project Pro • PT Power • Firepoint X • Northwest Trail • airTIGHT • ATAK

CLEAR VIEW EASY-FILL FUNNEL 1 GALLON

Item	Cross Part Number	Inner	Master	UPC
W4051	10705	1	72	039564148484

- Transparent polypropylene construction allows quick and easy monitoring of liquid
- Splash-resistant guard and bottle notches help limit spillage
- Contoured designed provides an easy-to-carry handle for holding and positioning
- Vented nozzle and wide opening enable filling at a high velocity
- Mesh filter prevents larger contaminants from entering your tank, radiator, or engine
- Integrated hang hole for convenient storage
- Approximate capacity: 3500ml, 3.7 Quarts, 0.92 gallons, 118.3 ounces



CLEAR VIEW LONG REACH FUNNEL 1 PINT

Item	Cross Part Number	Inner	Master	UPC
W4052	10718B24	1	144	039564014840

- Transparent polypropylene construction allows quick and easy monitoring of liquid
- Upgraded design features thicker construction, extended vent channels, and positive handholds
- Splash resistant guard and extended length provide quicker, cleaner transfer of liquid
- Integrated hang hole for convenient storage
- Approximate capacity: 500ml, 1.1 pints, 16.9 ounces



Wilmar, LLC • Performance Tool • Mechanics Products • Project Pro • PT Power • Firepoint X • Northwest Trail • airTIGHT • ATAK

3 PC. CLEAR VIEW FUNNELS (1/2 PT & 1 QT)

Item	Cross Part Number	Inner	Master	UPC
W4053	10714MX3	1	24	039564148491

- Transparent polypropylene construction allows quick and easy monitoring of liquid
- Features three distinct funnels for all your liquid filling needs: 1/2 pint multi-purpose long reach funnel, 1/2 pint Easy-Fill radiator funnel, and 1 quart Jr. Jumbo Easy-Fill funnel
- Having a different funnel for each liquid helps prevent cross contamination
- Integrated hang holes for convenient storage
- Approximate capacities: 200, 200, 800ml; 0.4, 0.4, 1.7 Pints; 6.8, 6.8, 27 ounces



CLEAR VIEW LONG REACH FUNNEL 1/2 PINT

Item	Cross Part Number	Inner	Master	UPC
W4054	10701BLK72	12	168	039564148507

- Transparent polypropylene construction allows quick and easy monitoring of liquid
- Great multi-purpose funnel for every day needs such as oil, coolant, gasoline, transmission fluid and more
- Splash guard directs fluid where you want it, and reduces spillage
- Integrated hang hole for convenient storage
- Approximate capacity: 200ml, 0.4 Pints, 6.8 Ounces



Wilmar, LLC • Performance Tool • Mechanics Products • Project Pro • PT Power • Firepoint X • Northwest Trail • airTIGHT • ATAK

CLEAR VIEW EASY HOLD FUNNEL 2 PINT

Item	Cross Part Number	Inner	Master	UPC
W4055	10709	1	64	039564148514

- Transparent polypropylene construction allows quick and easy monitoring of liquid
- Unique design holds standard quart sized oil bottles while they drain allowing hands-free operation
- Spout features concentric ridges that secure the funnel in your engine's filler hole
- Accommodates nearly all shapes and sizes of 1-quart oil bottles
- Integrated hang hole for convenient storage
- Approximate capacity: 800ml, 1.7 Pints, 27 Ounces



CLEAR VIEW EASY-FILL FUNNEL 1/2 PINT

Item	Cross Part Number	Inner	Master	UPC
W4056	10713 / 10703	1	144	039564148521

- Transparent polypropylene construction allows quick and easy monitoring of liquid
- Specifically designed with a shallow spout for use with radiators, but can also be used for oil, gas, and other fluids
- Notched lip works as a bottle rest for easier pouring
- Wide mouth openings for quick, high velocity pouring
- Splash guard helps reduce spillage
- Integrated hang hole for convenient storage
- Approximate capacity: 200ml, 0.4 Pints, 6.8 Ounces



Wilmar, LLC • Performance Tool • Mechanics Products • Project Pro • PT Power • Firepoint X • Northwest Trail • airTIGHT • ATAK



CLEAR VIEW EASY-FILL FUNNEL 1 QUART

Item	Cross Part Number	Inner	Master	UPC
W4057	10714WR	1	48	039564148538

- Transparent polypropylene construction allows quick and easy monitoring of liquid
- Large bowl area is designed to accommodate larger fluid bottles
- Oversized spout increases flow and fill rate
- Splash guard directs fluid where you want it, and reduces spillage
- Approximate capacity: 800ml, 1.7 Pints, 27 ounces



CLEAR VIEW XL REACH FUNNEL 1-1/2 PINT

Item	Cross Part Number	Inner	Master	UPC
W4058	10701	1	60	039564153884

- Transparent polypropylene construction allows quick and easy monitoring of liquid
- Notched lip works as a bottle rest for easier pouring
- Great extra-long reach, multi-purpose funnel for refilling transmission fluid, oil, and other engine fluids
- Splash guard directs fluid where you want it, and reduces spillage
- Integrated hang hole for convenient storage
- Approximate capacity: 780 ml, 1.65 Pints, 26.4 Ounces



Wilmar, LLC • Performance Tool • Mechanics Products • Project Pro • PT Power • Firepoint X • Northwest Trail • airTIGHT • ATAK



CAPLESS GAS TANK FUNNEL

Item	Cross Part Number	Inner	Master	UPC
W4086	10719	20	120	039564157608

- Flat Spout Allows Use with CARB Compliant Spouts
- For Adding Fuel Additives/Gas Or Other Liquids
- No-Mess Splash Guard
- Multiple Application Use
- Long Design For Long Spouts



DEF DIESEL EXHAUST FLUID FUNNEL

Item	Cross Part Number	Inner	Master	UPC
W4088	10732WR	12	72	039564157691

- No-mess splash guard
- Designed to fit DEF ports
- Wide basin for clean no mess pouring
- To prevent contamination, clean before each use
- Task-specific funnel engineered for specific use with diesel exhaust fluid



Wilmar, LLC • Performance Tool • Mechanics Products • Project Pro • PT Power • Firepoint X • Northwest Trail • airTIGHT • ATAK



ADBLUE® DEF FUNNEL W/MANUAL SHUT-OFF

Item	Cross Part Number	Inner	Master	UPC
W4050		1	16	039564156342

- This DEF filling funnel is designed to screw directly on to the AdBlue® tank filler neck to avoid spills
- Suitable for the urea tank connection
- Angled design, with plastic cover to protect against dust or dirt
- Built in filter and drip-free shut-off valve
- Embossed level indicators on the side of the transparent plastic funnel
- 1.1L (2.33 pints) capacity with filter
- Diameter 3.74 in. (95mm) Length 9.50 in. (241.3mm)
- Thread Size 1-3/16 in. (30.16mm) diameter. Spout is at a 45 Deg. Angle



1 QT. FUNNEL W/ FLEXIBLE SPOUT

Item	Cross Part Number	Inner	Master	UPC
W4087	05060MI	1	72	039564157592

- Ideal for hard to reach applications
- Detachable flexible spout
- Extra wide neck for high speed pouring
- No-mess splash guard design
- Accommodates nearly all shapes and sizes of 1-quart oil bottles



Wilmar, LLC • Performance Tool • Mechanics Products • Project Pro • PT Power • Firepoint X • Northwest Trail • airTIGHT • ATAK



1 QT. FUNNEL W/ON/OFF FLEXIBLE SPOUT

Item	Cross Part Number	Inner	Master	UPC
W4090	10704	1	72	039564157646

- On/Off Spout With Tube And Cap
- Accommodates nearly all shapes and sizes of 1-quart oil bottles

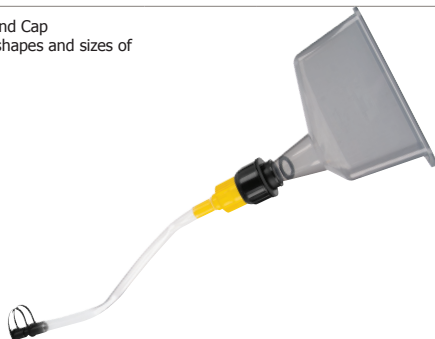

1/2 PINT ALL PURPOSE FUNNEL

Item	Cross Part Number	Inner	Master	UPC
W4007	05007	1	72	039564102912

- Great for dispensing petroleum based fluids and much more
- Extra long neck prevents spills
- Easy to use



Wilmar, LLC • Performance Tool • Mechanics Products • Project Pro • PT Power • Firepoint X • Northwest Trail • airTIGHT • ATAK



1 PINT ALL PURPOSE FUNNEL

Item	Cross Part Number	Inner	Master	UPC
W4015	05015	1	72	039564102929

- Great for dispensing petroleum based fluids and much more
- Extra long neck prevents spills
- Easy to use



1 QUART ALL PURPOSE FUNNEL

Item	Cross Part Number	Inner	Master	UPC
W4064		1	12	039564102943

- Great for dispensing petroleum based fluids and much more
- Extra wide mouth prevents spills
- Comes with hanging hook for convenient storage
- Easy to use



Wilmar, LLC • Performance Tool • Mechanics Products • Project Pro • PT Power • Firepoint X • Northwest Trail • airTIGHT • ATAK



2 QUART PLASTIC FUNNEL

Item	Cross Part Number	Inner	Master	UPC
W54276		1	10	039564542763

- Rugged, corrosion resistant all purpose funnel
- Complete with fine mesh straining screen and handy hanging tab
- Capacity indicates what the funnel will hold when the outlet is blocked



48 OZ. PLASTIC FUNNEL

Item	Cross Part Number	Inner	Master	UPC
W54275		1	24	039564542756

- Durable, oil and gasoline resistant plastic
- Safe for all petroleum products, complete with handy storage hanging tabs
- Capacity indicates what the funnel will hold when the outlet is blocked



Wilmar, LLC • Performance Tool • Mechanics Products • Project Pro • PT Power • Firepoint X • Northwest Trail • airTIGHT • ATAK



8 QT. STEEL GALVANIZED FUNNEL

Item	Cross Part Number	Inner	Master	UPC
W54272	LX-1708	1	12	039564542725

- Use this large-capacity funnel for filling drive casings, hydraulics, and other shop equipment
- Heavy-duty galvanized steel construction for weather-resistant year-round rugged use
- It has a rolled edge, a high splash-proof rim, and a fluted bottom to prevent liquids from swirling
- A grooved spout for air-venting, a 1 in. (25.4 mm) outlet I.D., with a removable strainer
- Capacity: 8 quarts (7.6 liters). Opening Diameter: 9-1/2 in. (24 cm). Height: 11-1/2 in. (29 cm).



2 PC. UNIVERSAL OIL FUNNEL

Item	Cross Part Number	Inner	Master	UPC
W4069		1	6	039564130984

- Hands free funnel helps to prevent spillage
- Innovative clamp keeps funnel in position allowing the user to pour with both hands
- Transparent lower chamber shows oil flow
- Universal design fits most foreign and domestic vehicles
- Funnel dimensions 257mm deep x 127mm diameter



Wilmar, LLC • Performance Tool • Mechanics Products • Project Pro • PT Power • Firepoint X • Northwest Trail • airTIGHT • ATAK



6 QT. STEEL GALVANIZED FUNNEL

Item	Cross Part Number	Inner	Master	UPC
W54299	LX-1706	1	12	039564153518

- Use this large-capacity funnel for filling drive casings, hydraulics, and other shop equipment
- Heavy-duty construction with an offset outlet to access awkwardly placed filler openings
- Galvanized steel construction for weather-resistant year-round rugged use
- It has a rolled edge, and a high splash-proof rim to prevent spills
- A grooved spout for air-venting, a 1-3/16 in. (3 cm) outlet I.D., with a removable strainer
- Capacity: 6 quarts (5.68 liters). Opening Diameter: 8-11/16 in. (22 cm). Height: 14-3/16 in. (36 cm)



EASY FUNNEL

Item	Cross Part Number	Inner	Master	UPC
W9167		12	144	039564000508

- Perfect for Pouring Hot and Cold Liquids
- US Patent 7,677,276B2
- Safe for Use With Detergents, Antifreeze, Lubricating Oils, Gasoline, Diesel Fuel
- Clips Onto Most Common Bottle Necks
- Easy One Handed Pouring
- Compact and Easy to Store
- Durable Polypropylene Construction



Wilmar, LLC • Performance Tool • Mechanics Products • Project Pro • PT Power • Firepoint X • Northwest Trail • airTIGHT • ATAK



18" FUNNEL

Item	Cross Part Number	Inner	Master	UPC
W4034	05034MI	1	12	039564102936

- Great for dispensing petroleum based fluids and much more
- Extra long neck prevents spills
- Easy to use
- Made of Polypropylene (PP), it provides strength and heat resistance



METAL FUNNEL W/12" FLEX SPOUT

Item	Cross Part Number	Inner	Master	UPC
W219	LX-1704	1	24	039564102295

- 6 diameter funnel with 12 spout
- Zinc plated



Wilmar, LLC • Performance Tool • Mechanics Products • Project Pro • PT Power • Firepoint X • Northwest Trail • airTIGHT • ATAK



PLASTIC FUNNEL W/18" SPOUT

Item	Cross Part Number	Inner	Master	UPC
W220	06064MI	1	50	039564102301

- 6 Diameter funnel
- 18 Flexible spout



2 PC. FLEX FUNNEL WITH HANDLE

Item	Cross Part Number	Inner	Master	UPC
W227	10733	1	24	039564102370

- Removable spout for multiple applications
- Easy hold handle



Wilmar, LLC • Performance Tool • Mechanics Products • Project Pro • PT Power • Firepoint X • Northwest Trail • airTIGHT • ATAK



SMALL ENGINE OIL CHANGE KIT

Item	Cross Part Number	Inner	Master	UPC
W4075		1	20	039564112928

- Extract used oil from small 4 stroke engines including mowers, weed whackers, blowers, and more
- Oil suction syringe extracts used oil through the enclosed 12 inch clear suction hose
- Empty the used oil into the temporary oil container for simple and hassle free oil changes
- Enclosed funnel is the perfect size to fit small oil fill ports on most 4 stroke equipment
- Microfiber towel traps dirt and grime, keeping the oil fill port clean



OIL FILTER REMOVAL CUP

Item	Cross Part Number	Inner	Master	UPC
W4085		1	12	039564155222

- Specially designed for removing oil filter to catch used engine oil
- Provides protection from heat and splashes associated with oil filter removal
- Safely holds oils, gasoline, diesel, and biofuels, any time a thread on filter is removed
- Helps avoid any spillage or contamination from engine oil
- Speed up your oil change service, allows for faster filter change-outs
- Use with any 3/8 and 1/2 in. Dr. oil filter cap wrenches
- The inside diameter of the oil catch cup is 6 in. (150 mm)



Wilmar, LLC • Performance Tool • Mechanics Products • Project Pro • PT Power • Firepoint X • Northwest Trail • airTIGHT • ATAK



FLUID TRANSFER





GRIP CLIP TRANSFER PUMP

Item	Cross Part Number	Inner	Master	UPC
W1156		6	24	039564106347

- Unique couplers offer far more holding power - no more messes from hoses coming loose
- Quick change fittings for easy attach and release
- Clear view barrel allows visual inspection
- Quickly transfers low-viscosity fluids, such as water and oils
- Also works as an air pump
- Includes: Hand-operated transfer pump, (2) 48 x 3/8 in. ID diameter clear view hoses, 15 in. air pressure hose, Snap-shut valve, Inflation needle
- US Patent D745,059



FLUID TRANSFER PUMP

Item	Cross Part Number	Inner	Master	UPC
W1141	10803	1	6	039564112539

- Fits all standard gallon bottles
- Quick Fit nozzle
- Each pump dispenses 1 oz of fluid
- Convenient and versatile for hard to reach places
- Eliminate mess and waste



Wilmar, LLC • Performance Tool • Mechanics Products • Project Pro • PT Power • Firepoint X • Northwest Trail • airTIGHT • ATAK



ON/OFF FLEXIBLE SPOUT

Item	Cross Part Number	Inner	Master	UPC
W4084	101068	10	60	039564157585

- On/off adjustable flow spout
- Reduced tip for transmission filler tubes
- Fits quart or gallon containers
- Clear spout to see what your pouring
- Easy-grip cap

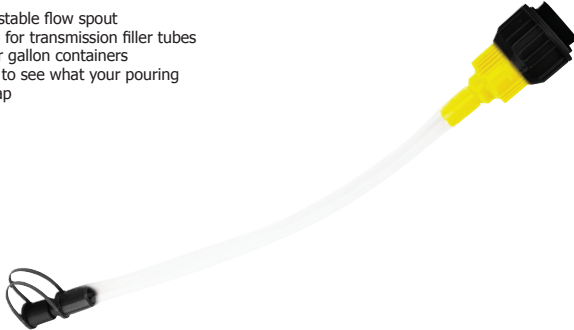

MULTI-USE TRANSFER PUMP

Item	Cross Part Number	Inner	Master	UPC
W1145	10803	6	24	039564112577

- Quickly and easily transfer any fluid
- Can be used as an air pump. Inflation needle not included
- (2qty) 3/8 in. ID X 52 in. long hoses



Wilmar, LLC • Performance Tool • Mechanics Products • Project Pro • PT Power • Firepoint X • Northwest Trail • airTIGHT • ATAK



5 GAL. PAIL PUMP W/FLEX HOSE

Item	Cross Part Number	Inner	Master	UPC
W54286	10804	1	20	039564132872

- Ideal for transferring mild chemicals, water based solutions, motor oils, and transmission fluid
- Durable pump delivers approx. 8 fluid ounces per stroke
- No more heavy lifting or messy pouring. Fits standard 5 gallon pails
- No special tools to install, flexible 22 in. clear discharge hose
- Suction Inlet includes a 1/2 in. barbed end if additional hose is needed
- Heavy duty 18 in. PVC body fit various small containers

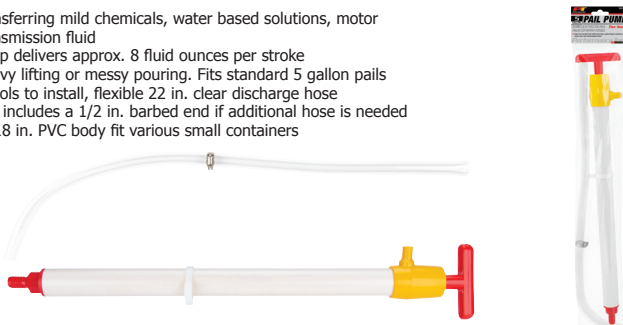

DELUXE RUBBER SIPHON HOSE

Item	Cross Part Number	Inner	Master	UPC
W1144	10800	12	96	039564112560

- All-purpose for transferring a variety of liquids, including oil, water, gasoline, or diesel
- Perfect for the seasonal transfer, or draining of liquids from lawn mowers or other equipment
- Easy to use, insert the siphon hose into the liquid, pump the bulb, and gravity does the rest
- Used in a wide range of professions, from DIY automotive maintenance to professional mechanic shops
- The 6 ft. PVC hose and rubber bulb are resistant to oil and gas, ensuring long-lasting durability

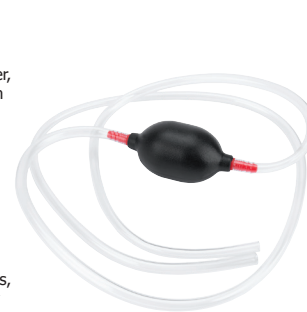

Wilmar, LLC • Performance Tool • Mechanics Products • Project Pro • PT Power • Firepoint X • Northwest Trail • airTIGHT • ATAK



12V OIL EXTRACTION PUMP

Item	Cross Part Number	Inner	Master	UPC
W54170		1	10	039564111068

- Our pump is portable, compact, lightweight and easy to use
- Efficiently remove up to 3 quarts per minute
- Easily removes oil from cars, motorcycles, RV's, boats and so much more
- Self priming 12v 5 amp DC pump
- Approx. speed 1400 RPM
- Includes: Pump, hose clamps and detailed instructions
- 47 inch x 0.16 inch dia. inlet hose, 59 inch x 0.47 inch dia. outlet hose



MANUAL OIL EXTRACTION PUMP

Item	Cross Part Number	Inner	Master	UPC
W54171		1	4	039564120510

- Conveniently remove oil or other liquids with no mess from spills or inconveniently accessed drain plugs
- Evacuates fluids including engine oil, transmission fluid, gear oil, coolant, and power steering fluid
- Small equipment including; lawn mower, tillers, generators, ATV's, motorcycles, or other 4-cycle engines
- Larger equipment including; cars, trucks, boats, farm, construction and much more
- Manually operated hand pump. Includes hoses needed to fit dip stick holes, or fill ports
- 8 Liters(2.11 Gal) Polyethylene constructed reservoir, large enough for most jobs
- Hose Length: Inlet 51 in. (129.5 cm.) Outlet 51 in. (129.5 cm.)



Wilmar, LLC • Performance Tool • Mechanics Products • Project Pro • PT Power • Firepoint X • Northwest Trail • airTIGHT • ATAK



BATTERY OPERATED TRANSFER PUMP

Item	Cross Part Number	Inner	Master	UPC
W54172		6	24	039564120657

- Easier and more convenient than your standard siphon pump
- This highly versatile battery operated pump is capable of 2.6 gallons per minute
- Pump fuel from your safety can to a generator, car, motorcycle, lawn equipment or any other fuel driven item. Works well with kerosene for heaters or stoves also
- Chemical fluids, cleaners, water (not for use with drinking water), light oil, etc
- Uses two D batteries (not included)



SHAKER SIPHON HOSE

Item	Cross Part Number	Inner	Master	UPC
W54154	10801	6	24	039564010828

- Shaker Siphon helps you transfer fluids with ease
- Moves up to 3.5 gallons a minute, through a 6-foot anti-static tube
- Safely transfer fuels, gasoline, diesel, water and many other liquids
- Great for home, farm, fleet, auto, marine and much more
- Simply shake the hose up and down to start the transfer
- Hose I.D. - 1/2 in



Wilmar, LLC • Performance Tool • Mechanics Products • Project Pro • PT Power • Firepoint X • Northwest Trail • airTIGHT • ATAK



LIQUID TRANSFER SHAKER SIPHON

Item	Cross Part Number	Inner	Master	UPC
W54155		12	24	039564121975

- Shaker siphon helps you transfer fluids with ease
- Moves up to 7 gallons per minute through a 6-foot anti-static tube
- Anti-static feature provides safe transfer of fuels such as Gasoline and Diesel
- Great for home, farm, fleet, auto, marine and much more
- Simply shake the tube up and down to start the transfer
- Hose I.D. - 3/4 in

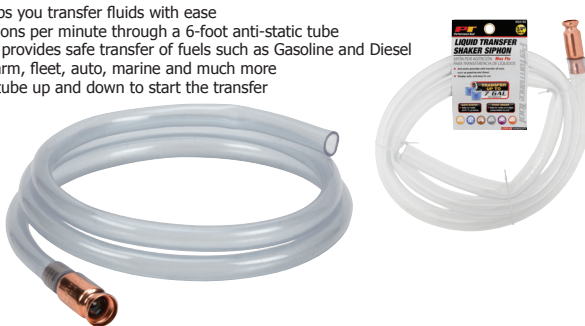

3-IN-1 FLEXIBLE SPOUT FUNNEL (BULK)

Item	Cross Part Number	Inner	Master	UPC
W4065		12	72	039564149443

- Easily add oil, coolant, or window cleaner from a gallon jug to any vehicle without mess or spills
- The double-threaded cap fits both gallon-size containers, standard (37 mm) and wide mouth (50 mm)
- Uniquely designed air bleed-off valve for faster and smoother fluid flow, up to five times faster
- A special rotary on-off switch helps effectively control the flow providing a positive shut-off
- The accordion-style spout is moldable and will hold its shape allowing for easier and more exact pours
- Collapsed its 10.25 in. (26 mm), fully extended its 15 in. (38.1 mm) long
- Patent Pending



Wilmar, LLC • Performance Tool • Mechanics Products • Project Pro • PT Power • Firepoint X • Northwest Trail • airTIGHT • ATAK



FLEXIBLE FUNNEL SPOUT

Item	Cross Part Number	Inner	Master	UPC
W4060	10101B12	6	36	039564148910

- Easily add oil, coolant, or window cleaner from a gallon jug to any vehicle without mess or spills
- The double-threaded cap fits both gallon-size containers, standard (37 mm) and wide mouth (50 mm)
- Uniquely designed air bleed-off valve for faster and smoother fluid flow, up to five times faster
- A special rotary on-off switch helps effectively control the flow providing a positive shut-off
- The accordion-style spout is moldable and will hold its shape allowing for easier and more exact pours
- Collapsed its 10.25 in. (26 mm), fully extended its 15 in. (38.1 mm) long
- Patent Pending



FLEX SPOUT

Item	Cross Part Number	Inner	Master	UPC
W4061		20	80	039564154942

- Use for adding motor oil, transmission fluid, anti-freeze or windshield washer fluid without a mess
- Accordion style spout works great to access hard-to-reach areas
- The inlet has dual threads to fit most quart and gallon containers
- A perfect spout for adding small amounts of oil to lawn and yard equipment
- Not designed for use with gasoline containers
- Retracted it's 7 in. (17.8 cm), extended it's 10-1/2 in. (26.7 cm)



Wilmar, LLC • Performance Tool • Mechanics Products • Project Pro • PT Power • Firepoint X • Northwest Trail • airTIGHT • ATAK



SIPHON HOSE W/BACK FLOW VALVE

Item	Cross Part Number	Inner	Master	UPC
W54156		6	24	039564130595

- Safely transfer most liquids from one container to another with ease
- Back flow valve prevents unwanted reverse flow of any liquid
- Siphon pump allows quick and easy transfer of gasoline, water and most other liquids
- The rubber squeeze pump and one way valve generates quick suction to start the siphon
- Two 32 in. oil and gas resistant hoses give you plenty of reach for deep containers



QUART/GALLON FLUID PUMP

Item	Cross Part Number	Inner	Master	UPC
W1139		6	48	039564112744

- Unique double threaded cap fits both quart and gallon size containers
- Convenient and versatile for hard to reach places
- Eliminates mess and waste
- Pumps approx. 5cc per stroke
- US Patent 7,857,172



Wilmar, LLC • Performance Tool • Mechanics Products • Project Pro • PT Power • Firepoint X • Northwest Trail • airTIGHT • ATAK



MARINE LOWER UNIT FLUID PUMP

Item	Cross Part Number	Inner	Master	UPC
W54150		12	48	039564106354

- Patented double threaded cap fits both the quart and gallon size lubricant
- 24" flexible hose easily reaches difficult to access fill plugs
- 3/8-16 fits: OMC, Mercruiser, Evinrude, Johnson, Volvo, Force, Honda 70hp and up, and Mercury US origin
- 8mm fits: Yamaha, Nissan, Tohatsu, small Honda's, and Mercury Japanese origin
- US Patent 7,857,172



STANDARD & WIDE MOUTH GALLON FLUID PUMP

Item	Cross Part Number	Inner	Master	UPC
W1140		6	48	039564143427

- Unique double threaded cap fits both gallon size containers, standard (37mm) and wide mouth (50mm)
- Simple and effective solution for adding lubricants to automotive, farm, and industrial equipment
- Avoid spills changing fluids like gear lube in a differential
- Threads securely onto traditional 37mm and the new 50mm wide mouth gallon containers
- The inlet plastic hose cut to fit to ensure you reach the bottom of your container

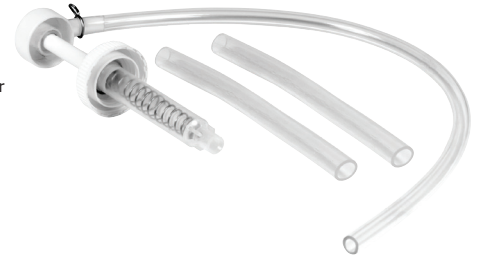

Wilmar, LLC • Performance Tool • Mechanics Products • Project Pro • PT Power • Firepoint X • Northwest Trail • airTIGHT • ATAK



SIPHON PUMP

Item	Cross Part Number	Inner	Master	UPC
W1142		24	120	039564112546

- All purpose
- Oil and gas resistant



DRILL PUMP

Item	Cross Part Number	Inner	Master	UPC
W1143		12	36	039564112553

- Ideal for transferring liquids in a variety of applications
- Used in combination with a corded or cordless drill and standard garden hoses
- Minimum drill speed 1200 RPM gives a water lift of 3.28-feet, and 225 gallons per hour
- Two male 3/4 in. garden thread fittings for suction & discharge, 3/4 in. max hose diameter
- Self-priming with a corrosion-resistant shaft and thermoplastic construction



Wilmar, LLC • Performance Tool • Mechanics Products • Project Pro • PT Power • Firepoint X • Northwest Trail • airTIGHT • ATAK



BLUE GENERAL PURPOSE LEVER ACTION PUMP

Item	Cross Part Number	Inner	Master	UPC
W54268		1	12	039564542688

- Fits 5 gallon to 55 gallon drums
- Ideal for fuel, water based and acidic solutions
- 9 oz. per 1 stroke



GENERAL PURPOSE LEVER ACTION PUMP

Item	Cross Part Number	Inner	Master	UPC
W54269		1	12	039564542695

- Fits 5 gallon to 55 gallon drums
- Ideal for fuel, water based and acidic solutions
- 9 oz. per 1 stroke



Wilmar, LLC • Performance Tool • Mechanics Products • Project Pro • PT Power • Firepoint X • Northwest Trail • airTIGHT • ATAK



PROFESSIONAL BARREL PUMP

Item	Cross Part Number	Inner	Master	UPC
W54267		1	10	039564542671

- Lever style barrel pump with non drip spout
- Equipped with brass rings and a floating piston design
- Self adjusting telescopic suction tube
- Designed to pump all lubrication based fluids, antifreeze, agricultural and industrial non corrosive fluids
- Dispenses approximately 12 oz. per 1 stroke
- Multi directional handle



T-HANDLE BARREL PUMP

Item	Cross Part Number	Inner	Master	UPC
W54266		1	12	039564542664

- Features die cast head with garden hose threads
- 18 gauge steel cylinder
- Includes curved metal spout and adapter



Wilmar, LLC • Performance Tool • Mechanics Products • Project Pro • PT Power • Firepoint X • Northwest Trail • airTIGHT • ATAK



ROTARY BARREL PUMP

Item	Cross Part Number	Inner	Master	UPC
W54270		1	6	039564542701

- For transferring non corrosive petroleum based fluids of light to medium viscosity
- For industrial, commercial, automotive and agricultural applications
- Single direction 2 vane pump with rugged cast iron housing and 42" steel suction pipe
- Low viscosity material transfer - 1 gallon with every 12 full revolutions



LEVER ACTION DISPENSER

Item	Cross Part Number	Inner	Master	UPC
W54232		1	6	039564542329

- Perfect for dispensing transmission and other heavier fluids
- Contains pump, 4' delivery hose and bucket/barrel cover
- Fits most 25 to 50lb buckets



Wilmar, LLC • Performance Tool • Mechanics Products • Project Pro • PT Power • Firepoint X • Northwest Trail • airTIGHT • ATAK



DEF ROTARY BARREL PUMP

Item	Cross Part Number	Inner	Master	UPC
W54285		1	6	039564107351

- Professional rotary barrel pump is ideal for DEF (Diesel Exhaust Fluid)
- Also resistant to gasoline, diesel, machine oil, alcohol, acidic fluids and much more
- Fits all 5-55 gallon pails/drums with a standard bung fitting
- Hand-operated rotary lever action delivers approx. 7 gallons per 100 revolutions
- Polypropylene body with PTFE vanes aids in resistance to harsh chemicals
- One way check valve to aid in the prevention of product contamination



SUCTION GUN

Item	Cross Part Number	Inner	Master	UPC
W54220		1	20	039564542206

- Professional quality heavy duty construction for long service life
- Perfect for transmissions, differentials, gear cases, lower units, crankcases, etc
- Zinc head, 12in. flexible hose, and 1 pint total capacity
- No priming necessary, just submerge the hose end and draw the handle back
- Black Powder coating, knurled barrel provides corrosion protection and positive grip



Wilmar, LLC • Performance Tool • Mechanics Products • Project Pro • PT Power • Firepoint X • Northwest Trail • airTIGHT • ATAK



6 OZ. PISTOL OILERS

Item	Style	Inner	Master	UPC
W54265	Flex Hose	6	24	039564542657
W54264	Rigid Hose	6	24	039564542640

- Drawn steel body
- Durable epoxy finish
- Size: 6 oz



1/4 PT. PUMP OILER W/FLEX SPOUT

Item	Cross Part Number	Inner	Master	UPC
W241		6	60	039564102523

- Flexible spout
- Precision steel pump
- Convenient sizes
- Size: 1/4 Pint



Wilmar, LLC • Performance Tool • Mechanics Products • Project Pro • PT Power • Firepoint X • Northwest Trail • airTIGHT • ATAK



3/4 PT. PUMP OILER W/FLEX SPOUT

Item	Cross Part Number	Inner	Master	UPC
W242		6	36	039564102530

- Flexible spout
- Brass pump
- Convenient sizes
- Size: 3/4 Pint



1 PT. PUMP OILER W/FLEX SPOUT

Item	Cross Part Number	Inner	Master	UPC
W54263		1	24	039564542633

- Drawn steel body
- Durable epoxy finish
- Size: 1 Pint



Wilmar, LLC • Performance Tool • Mechanics Products • Project Pro • PT Power • Firepoint X • Northwest Trail • airTIGHT • ATAK



Wilmar, LLC • Performance Tool • Mechanics Products • Project Pro • PT Power • Firepoint X • Northwest Trail • airTIGHT • ATAK

2-1/2 GAL. PLASTIC RADIATOR FILLER

Item	Cross Part Number	Inner	Master	UPC
W54273		1	4	039564542732

- Tough polyethylene won't damage automotive finishes
- Impervious to oil, gasoline and antifreeze
- Will withstand normal temperature extremes



5 QT. FLEX-SPOUT MEASURING DISPENSER

Item	Cross Part Number	Inner	Master	UPC
W54279	LX-1536	1	4	039564542794

- Designed for one hand operation
- Thumb operated valve controls flow, flip action locks valve open
- 14 in. flexible metal spout with tapered 1/2 in. OD tip swings into the necessary angle for hard to reach jobs
- Recessed bottoms drain fully and guard against puncture
- Rolled edge top helps prevent oil spillage



4 QT. GALVANIZED MEASURING DISPENSER

Item	Cross Part Number	Inner	Master	UPC
W54278	LX-1524	1	6	039564542787

- Deluxe measures with spill proof tops
- Angled spouts for ease of pouring
- Rolled edge, easy grip handles
- Calibrated fill line



Wilmar, LLC • Performance Tool • Mechanics Products • Project Pro • PT Power • Firepoint X • Northwest Trail • airTIGHT • ATAK

5 QUART OIL JUG W/LID

Item	Cross Part Number	Inner	Master	UPC
W4046		1	16	039564154522

- Oil jug is made from high-quality chemical resistant plastic
- Measurements are mark in quarts and liters
- Tight fitting lid and pour spout protect the fluid inside the cup from dust and other contamination
- Sturdy handle makes pouring safer and easier
- Flexible spout allows user to reach tight areas while pouring
- Capacity 5 quart, 4730 ml, 160 ounces



35 OZ. MEASURING CUP W/LID

Item	Cross Part Number	Inner	Master	UPC
W4047		1	24	039564154539

- Measuring cup is made from high-quality chemical resistant plastic
- Measurements are marked in fluid ounces and milliliters
- Measurements are marked in both black and clear to remain visible with use of any color fluid
- Tight fitting lid and pour spout protect the fluid inside the cup from dust and other contamination
- Sturdy handle makes pouring safer and easier
- Capacity 1 quart, 1000 ml, 35 ounces



Wilmar, LLC • Performance Tool • Mechanics Products • Project Pro • PT Power • Firepoint X • Northwest Trail • airTIGHT • ATAK

200CC EXTRACTION & FILL PUMP

Item	Cross Part Number	Inner	Master	UPC
W54173		12	24	039564131974

- Remove brake fluid, coolant, gear oil, or power steering fluid prior to brake work or other repairs
- Unique hose coupler offers a positive hose connection, but still easy to remove
- The body of the cylinder is calibrated with both English & Metric measurements
- When the jobs complete, it's easy to disassemble for cleaning. Hose and seals are easily replaced
- Easily disassembled for cleaning, allowing the mechanic to use a multitude of different fluids
- Includes two 7-1/2 in. hoses; one 5/16 in. and one 1/4 in. with a coupler to join them together



1500CC EXTRACTION & FILL PUMP

Item	Cross Part Number	Inner	Master	UPC
W54177		1	10	039564153914

- Designed to remove and fill brake fluid, coolant, anti-freeze, gear oil, power steering fluid, and more
- Semi-translucent cylinder for viewing exact fluid volume and overall fluid condition
- Double seals for reliability against harsh liquids, and is easily disassembled for cleaning
- Heavy-duty construction with a removable handle for better management of the pump



Wilmar, LLC • Performance Tool • Mechanics Products • Project Pro • PT Power • Firepoint X • Northwest Trail • airTIGHT • ATAK



WHEEL CHOCKS

Item	Cross Part Number	Inner	Master	UPC
W41000		1	48	039564389931

- Keeps tires from rolling
- Safety device for use with ramps or other lifting devices



SOLID RUBBER WHEEL CHOCK

Item	Cross Part Number	Inner	Master	UPC
W41001		1	8	039564072826

- Ideal to keep your vehicle or trailer in place in any climate
- All weather construction with rubber traction pad
- Oil resistant non-slip surface provides superior traction
- Weighs less than 5 pounds
- Specs: 45° slope angle, Wheel contact area: 7-1/2" L x 3-57/64" W, Base size: 7-3/4" x 3-31/32", Chock height: 5-7/8", Handle: 5-5/8" L x 1-5/16" W x 1" H

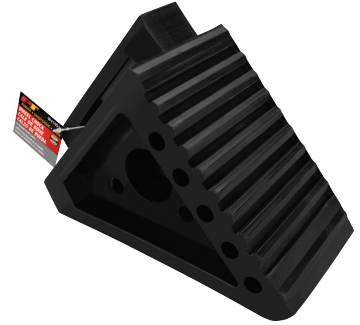

Wilmar, LLC • Performance Tool • Mechanics Products • Project Pro • PT Power • Firepoint X • Northwest Trail • airTIGHT • ATAK



STACKABLE 16,000 LB. GVW VEHICLE RAMPS

Item	Cross Part Number	Inner	Master	UPC
W41014	11912MI	1	1	039564155239

- 16,000 lb. (7,272 kg) total gross vehicle weight capacity allows safe performance of repair and maintenance underneath your vehicle
- Patented stackable design utilizes reinforced channels to nest and save space while in storage
- Raised stop end provides added strength and stability
- Molded traction treads and gentle 17-degree incline provide easy loading even for low clearance vehicles
- Specifications: maximum 4,000 lb. (1,818 kg) per ramp, 8,000 lb. (3,636 kg) per pair working load capacity



13,000 LB. GVW VEHICLE RAMPS

Item	Cross Part Number	Inner	Master	UPC
W41013	11909MI	1	1	039564153334

- 13,000 lb. (5,909 kg) total gross vehicle weight capacity allows safe performance of repair and maintenance underneath your vehicle
- Concave wheel rest surface and raised stop end provide added strength and stability
- Molded traction treads and gentle 17-degree incline provide easy loading even for low clearance vehicles
- Openings in the side and low end allow for easy carrying, positioning, and hanging ramps in storage
- Specifications: maximum 3,250 lb. (1,477 kg) per ramp, 6,500 lb. (2,955 kg) per pair working load capacity



Wilmar, LLC • Performance Tool • Mechanics Products • Project Pro • PT Power • Firepoint X • Northwest Trail • airTIGHT • ATAK



ABSORBENT FLOOR MATS

Item	Size	Inner	Master	UPC
W88801	9 FT. X 2.4 FT.	1	5	039564150371
W88802	18 FT. X 2.4 FT.	1	5	039564150388
W88803	20 FT. X 7.4 FT.	1	2	039564015038

- Made of high quality felt with hot-melt adhesive backing to reduce moisture seepage and slipping
- Helps reduce the spreading of dirt, grease, or any mess
- Easily cut to fit any desired shape and place with double sided tape (included)
- Hang dry only, do not use harsh chemicals or bleach when cleaning



5 GALLON OIL LIFT DRAIN

Item	Cross Part Number	Inner	Master	UPC
W54282	LX-1712	1	1	039564542824

- Telescopic tube adjusts to desired height
- Range 40 1/2" to 60" with 13 1/2" diameter funnel
- Comes complete with heavy duty 5 gallon container
- Telescopic tube and sturdy funnel



Wilmar, LLC • Performance Tool • Mechanics Products • Project Pro • PT Power • Firepoint X • Northwest Trail • airTIGHT • ATAK



TRANSMISSION DRAIN ADAPTER PAN

Item	Cross Part Number	Inner	Master	UPC
W54281	LX-1638	1	5	039564542817

- For lift drains
- Heavy duty, high density polyethylene
- Small diameter drain holes in bottom of pan prevent loss of pan bolts
- 24" diameter



ROLLING BASE FOR LIFT DRAIN

Item	Cross Part Number	Inner	Master	UPC
W54283	LX-1713	1	4	039564542831

- Heavy duty steel construction
- Baked enamel finish
- Ball bearing type casters
- For use with Performance Tool part #W54282



Wilmar, LLC • Performance Tool • Mechanics Products • Project Pro • PT Power • Firepoint X • Northwest Trail • airTIGHT • ATAK



FENDER COVER

Item	Cross Part Number	Inner	Master	UPC
W80583		1	12	039564805837

- Heavy duty vinyl with foam backing
- Convenient built in tool pockets
- Fully sewn ribbed edge
- Size: 33" x 24"



ALUMINUM BUNG WRENCH

Item	Cross Part Number	Inner	Master	UPC
W54160		1	40	039564148071

- Used to remove 2 in. and 3/4 in. bung caps on most 15, 30, and 55 gallon drums
- The offset handle design works well on recessed countersunk bung caps
- The wrench used in agriculture, construction, industrial, vehicle, and fleet service applications
- Universal, fits most metal or plastic water, diesel, chemical, oil, and fuel drums caps
- For metal or plastic caps/bungs, size 2 in., 3/4 in., length 10-5/16 in., lightweight 6.3 ounces (0.18kg.)



Wilmar, LLC • Performance Tool • Mechanics Products • Project Pro • PT Power • Firepoint X • Northwest Trail • airTIGHT • ATAK



HEAVY DUTY 32 OZ. SPRAY BOTTLE

Item	Cross Part Number	Inner	Master	UPC
W1473		12	24	039564134678

- Chemical-resistant heavy duty sprayer bottle that holds up to harsh cleaners and solvents
- High output fluid nozzle that can dispense large volumes down to a light mist
- Molded fingertip trigger helps reduce finger fatigue during rigorous use
- Full range adjustable nozzle for: Fine mist, coarse spray, and jet stream
- Handy oz. and mL scale molded into the side of the bottle for accurate measurement
- The perfect multipurpose spray bottle for the garage, household, or shop



40 PK. INDUSTRIAL MECHANIC WIPES

Item	Cross Part Number	Inner	Master	UPC
W1479		1	16	039564144868

- The heaviest duty wipes you will ever find!
- Water-saving, moisturizing, eco-friendly and featuring a fresh lemon scent
- Powerful ingredients combine three different oils that clean the toughest of dirt, grease, grime, oil, paint, tar, sludge, silicone, adhesives and more
- Unlike water-based wipes, these feature lemon oil, olive oil, and mineral oil to remove everything other wipes leave behind



Wilmar, LLC • Performance Tool • Mechanics Products • Project Pro • PT Power • Firepoint X • Northwest Trail • airTIGHT • ATAK



25 PK. RED SHOP TOWELS

Item	Cross Part Number	Inner	Master	UPC
W1476		1	24	039564105654

- Machine washable
- Soft all-cotton weave
- Picks up dirt, grease and liquids
- 13.75 in. x 13 in. (33 x 35 cm)



12 PK. MICROFIBER TOWELS

Item	Cross Part Number	Inner	Master	UPC
W1482		1	20	039564151224

- Clean without harsh chemicals, scratching or leaving lint
- Textured cloth lifts and traps dust to prevent scratches
- Nonabrasive for delicate surfaces
- Machine wash and dry
- Approximate size: 12 in. x 16 in. (30 cm x 40 cm)
- Cloth weight: 200g/m2, 83% polyester, 17% polyamide



Wilmar, LLC • Performance Tool • Mechanics Products • Project Pro • PT Power • Firepoint X • Northwest Trail • airTIGHT • ATAK



PT Performance Tool
MERCHANDISER OPTIONS

Wilmar, LLC • Performance Tool • Mechanics Products • Project Pro • PT Power • Firepoint X • Northwest Trail • airTIGHT • ATAK

PT Performance Tool CLEAR VIEW EASY-FILL FUNNEL 1 GALLON

Item	Cross Part Number	Inner	Master	UPC
W4091	10705	12	48	039564150340

- Transparent polypropylene construction allows quick and easy monitoring of liquid
- Splash-resistant guard and bottle notches help limit spillage
- Contoured designed provides an easy-to-carry handle for holding and positioning
- Vented nozzle and wide opening enable filling at a high velocity
- Mesh filter prevents larger contaminants from entering your tank, radiator, or engine
- Approximate capacity: 3500ml, 3.7 Quarts, 0.92 gallons, 118.3 ounces

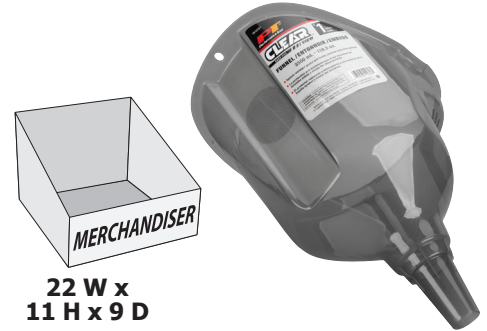

22 W x 11 H x 9 D

PT Performance Tool CLEAR VIEW LONG REACH FUNNEL 1 PINT

Item	Cross Part Number	Inner	Master	UPC
W4092	10718B24	12	144	039564150357

- Transparent polypropylene construction allows quick and easy monitoring of liquid
- Upgraded design features thicker construction, extended vent channels, and positive handholds
- Splash resistant guard and extended length provide quicker, cleaner transfer of liquid
- Integrated hang hole for convenient storage
- Approximate capacity: 500ml, 1.1 pints, 16.9 ounces

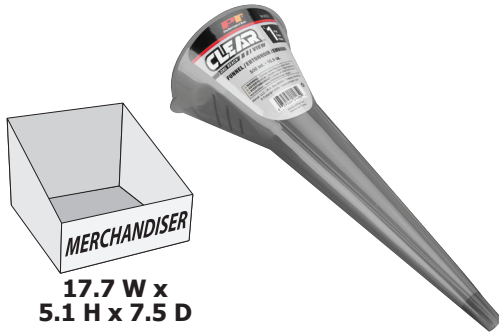

17.7 W x 5.1 H x 7.5 D

PT Performance Tool 3 PC. CLEAR VIEW FUNNELS (1/2 PT & 1 QT)

Item	Cross Part Number	Inner	Master	UPC
W4093	10714MX3	6	24	039564154287

- Transparent polypropylene construction allows quick and easy monitoring of liquid
- Features three distinct funnels for all your liquid filling needs: 1/2 pint multi-purpose long reach funnel, 1/2 pint Easy-Fill radiator funnel, and 1 quart Jr. Jumbo Easy-Fill funnel
- Having a different funnel for each liquid helps prevent cross contamination
- Integrated hang holes for convenient storage
- Approximate capacities: 200, 200, 800ml; 0.4, 0.4, 1.7 Pints; 6.8, 6.8, 27 ounces

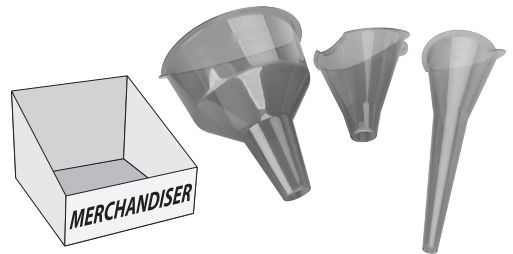

15.75 W x 11 H x 10.2 D

Wilmar, LLC • Performance Tool • Mechanics Products • Project Pro • PT Power • Firepoint X • Northwest Trail • airTIGHT • ATAK

PT Performance Tool CLEAR VIEW LONG REACH FUNNEL 1/2 PINT

Item	Cross Part Number	Inner	Master	UPC
W4094	10701BLK72	12	168	039564154317

- Transparent polypropylene construction allows quick and easy monitoring of liquid
- Great multi-purpose funnel for every day needs such as oil, coolant, gasoline, transmission fluid and more
- Splash guard directs fluid where you want it, and reduces spillage
- Integrated hang hole for convenient storage
- Approximate capacity: 200ml, 0.4 Pints, 6.8 Ounces

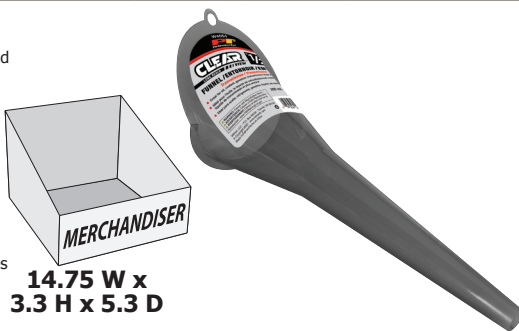

14.75 W x 3.3 H x 5.3 D

PT Performance Tool CLEAR VIEW EASY HOLD FUNNEL 2 PINT

Item	Cross Part Number	Inner	Master	UPC
W4095	10709	12	72	039564158131

- Transparent polypropylene construction allows quick and easy monitoring of liquid
- Unique design holds standard quart sized oil bottles while they drain allowing hands-free operation
- Spout features concentric ridges that secure the funnel in your engine's filler hole
- Accommodates nearly all shapes and sizes of 1-quart oil bottles
- Integrated hang hole for convenient storage
- Approximate capacity: 800ml, 1.7 Pints, 27 Ounces



13.8 W x 4.1 H x 3.3 D

Wilmar, LLC • Performance Tool • Mechanics Products • Project Pro • PT Power • Firepoint X • Northwest Trail • airTIGHT • ATAK

PT Performance Tool CLEAR VIEW EASY-FILL FUNNEL 1/2 PINT

Item	Cross Part Number	Inner	Master	UPC
W4096	10713 / 10703	12	144	039564158148

- Transparent polypropylene construction allows quick and easy monitoring of liquid
- Specifically designed with a shallow spout for use with radiators, but can also be used for oil, gas, and other fluids
- Notched lip works as a bottle rest for easier pouring
- Wide mouth openings for quick, high velocity pouring
- Splash guard helps reduce spillage
- Integrated hang hole for convenient storage
- Approximate capacity: 200ml, 0.4 Pints, 6.8 Ounces

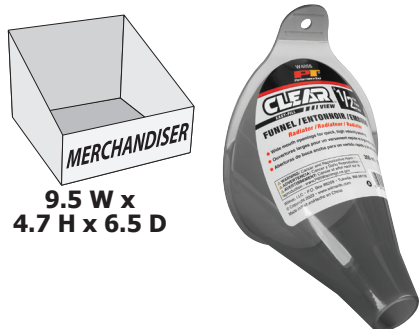

9.5 W x 4.7 H x 6.5 D

PT Performance Tool CLEAR VIEW EASY-FILL FUNNEL 1 QUART

Item	Cross Part Number	Inner	Master	UPC
W4097	10714WR	12	48	039564158155

- Transparent polypropylene construction allows quick and easy monitoring of liquid
- Large bowl area is designed to accommodate larger fluid bottles
- Oversized spout increases flow and fill rate
- Splash guard directs fluid where you want it, and reduces spillage
- Approximate capacity: 800ml, 1.7 Pints, 27 ounces

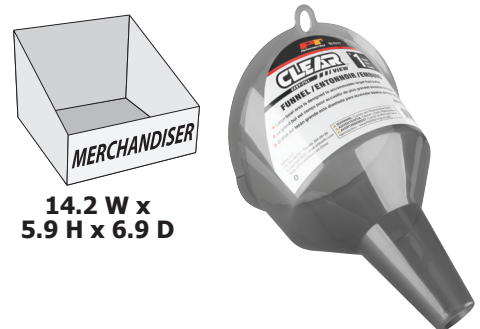

14.2 W x 5.9 H x 6.9 D

Wilmar, LLC • Performance Tool • Mechanics Products • Project Pro • PT Power • Firepoint X • Northwest Trail • airTIGHT • ATAK